

# Metal Garden Bed

## Instructions for Assembly

---

Size: L78.7"xW39.3"xH30"

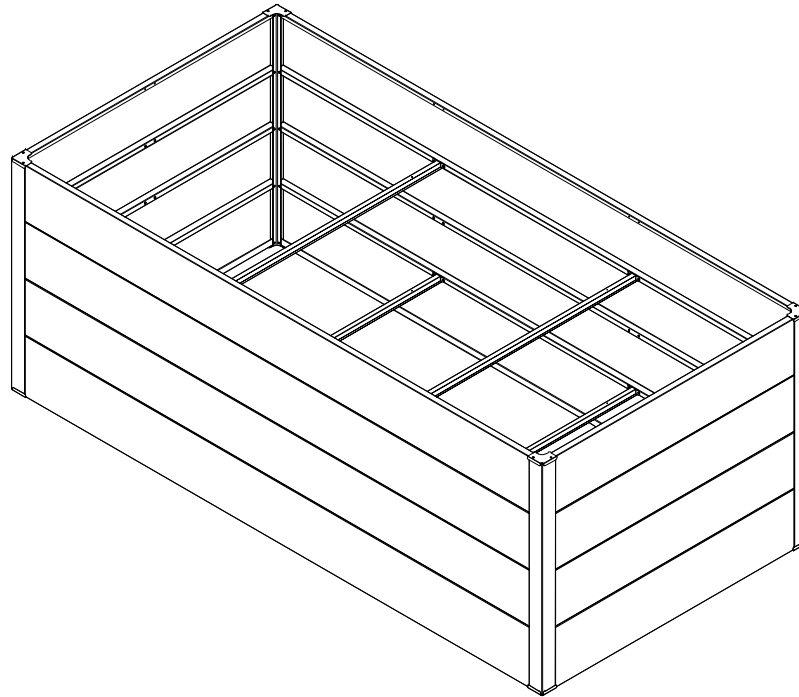

**9820503**

Requires two people and takes 1 hour for Installation.

Quick & Easy Assembly

Ridge Reinforced Walls

Available in Various Sizes



# IMPORTANT

If you have any problems with this product, please

**DO NOT RETURN THIS ITEM**

To the Retailer/Store from where you purchased the product.

Please email us anytime with the nature of the problem at:

**ContactUs@Hanover-Products.com**

Please include:

- Pictures of the issue(s) and receipt (if available)
- Name and address of the Purchaser
- Name of retailer

Or call our Customer Service team between 9:00 AM and 5:00 PM Eastern Time,  
Monday through Friday at:

**1-877-397-5144**

or visit our website at:

**www.Hanover-Products.com**

To expedite any future warranty claims, please retain your receipt for future use.





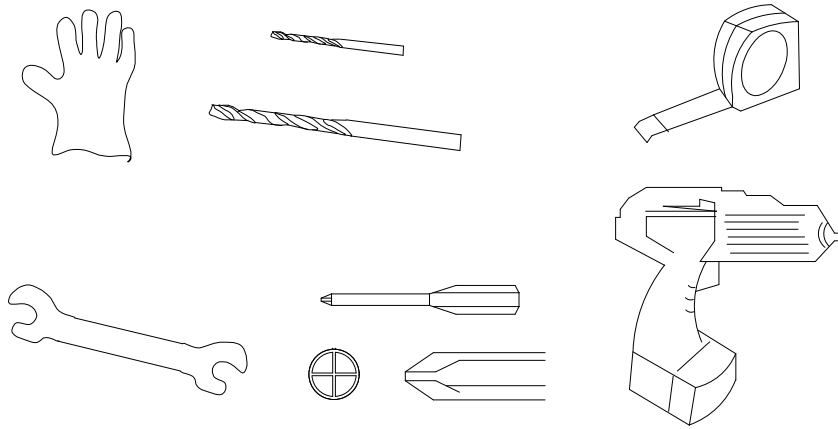

For additional on-line support on assembly, troubleshooting and care & maintenance of your outdoor product, please visit our website at: **www.Hanover-Products.com**.

8/1/2019

## Required Tools

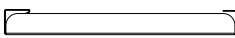

Use heavy duty gloves when handling steel sheets and flashing

NO.	PART	Qty.
C1	 754mm 29.7"	4
C	 984mm 38.7"	4
P1	 1947 mm 76.6"	6
P3	 1947 mm 76.6"	2
P2	 947 mm 37.2"	6
P4	 947 mm 37.2"	2
S5		8
F1		104

# Explosive Drawing

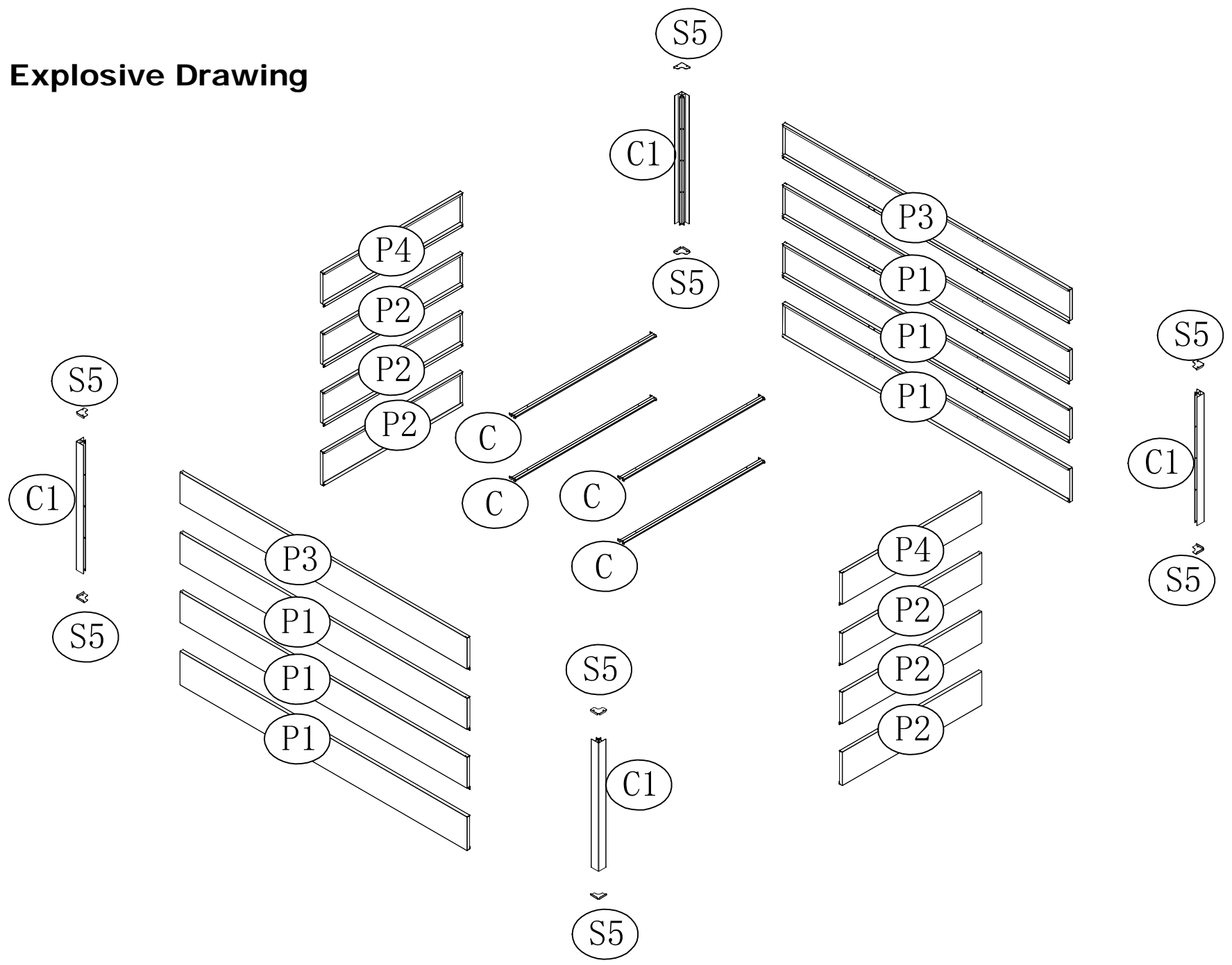

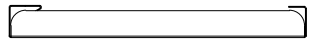

P3 x 2



P1 x 6

### Wall Panels Assembly (4 panels for one wall)

Hook the 4 panels together and lay down them on flat ground

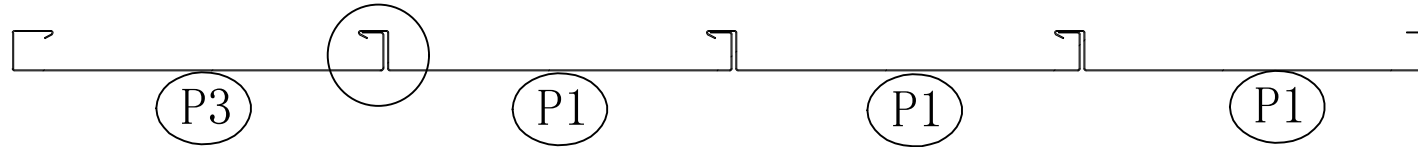

P3 is the Top Panel  
The shape is different from that of P1.

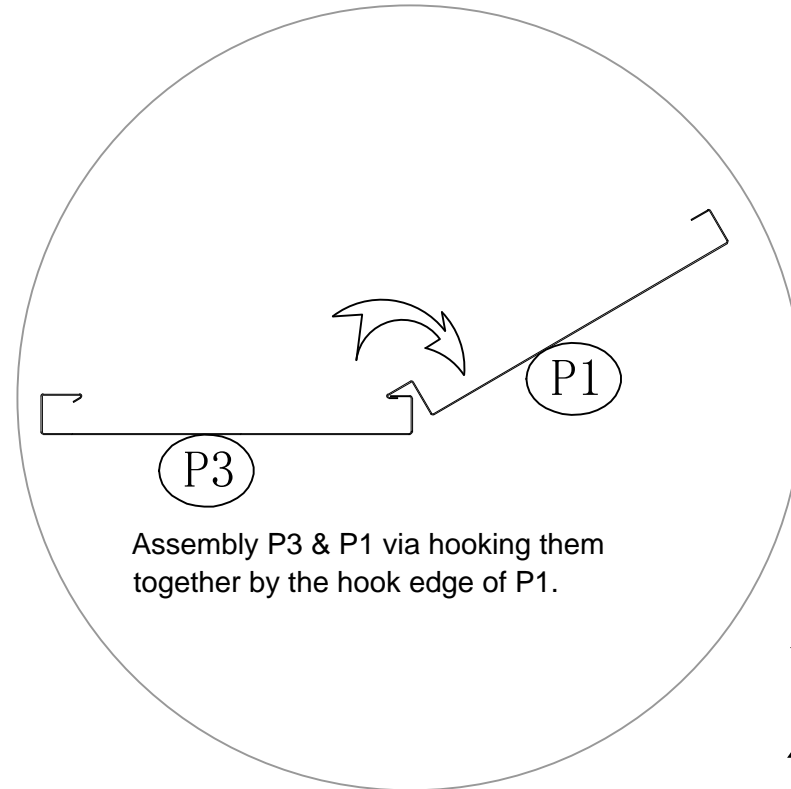
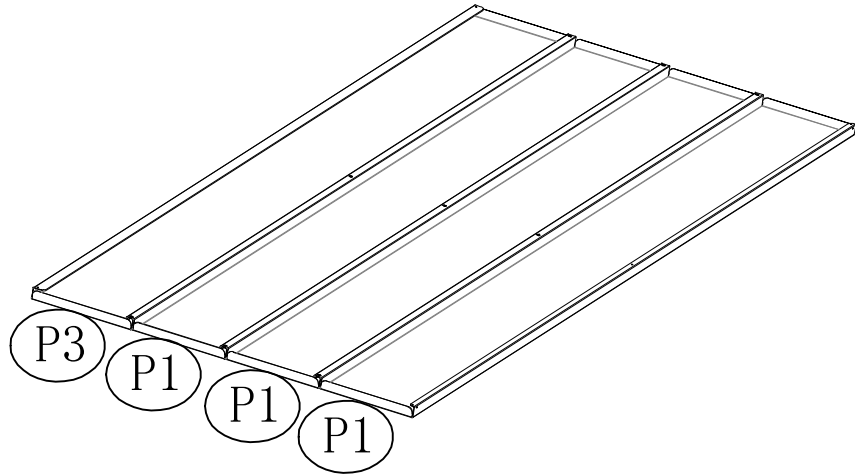

Assembly P3 & P1 via hooking them together by the hook edge of P1.

**x2**

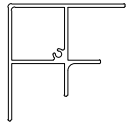

C1 x 4



F1 x 20

### Corner Posts Assembly

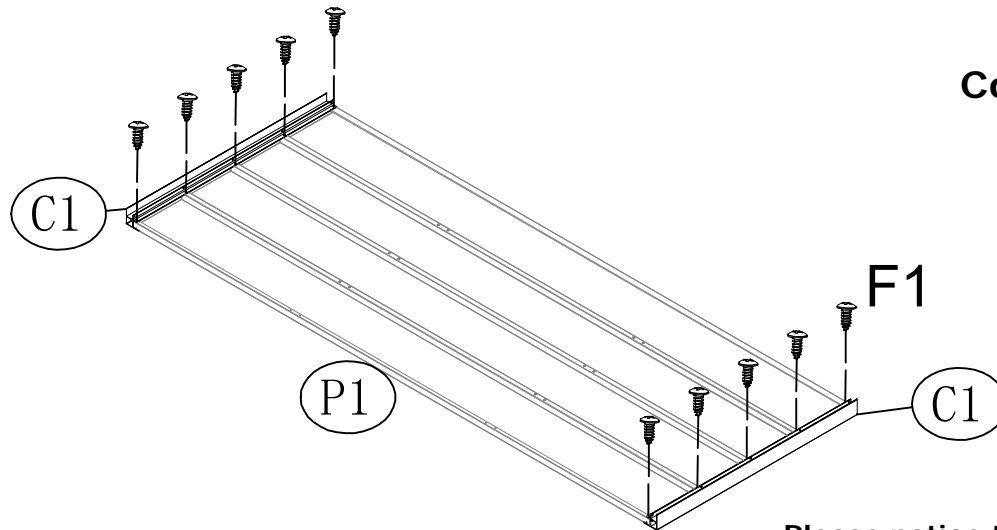

Please notice the posts are assembled on the two short edges of assembled wall panel.

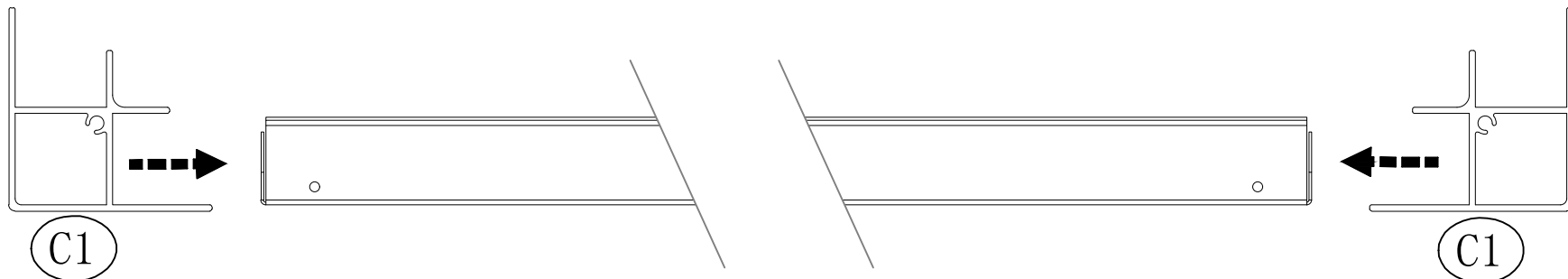

Attach the corner post C1 to the assembled wall panel in previous step.  
Ensure the edges of panels are all contented in the groove of profile of corner post C1.

x2

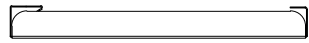

P4 x 2



P2 x 6

## Wall Panels Assembly

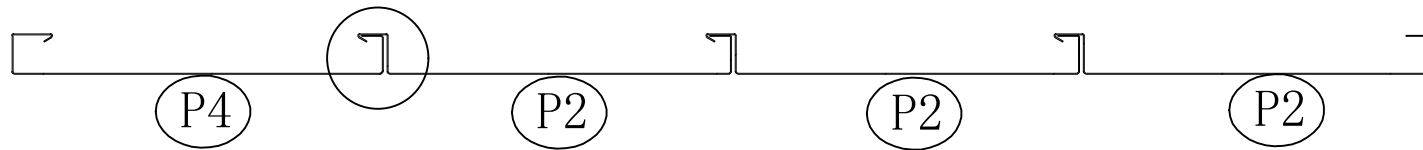

Repeat the wall panels assembly for other two side walls.

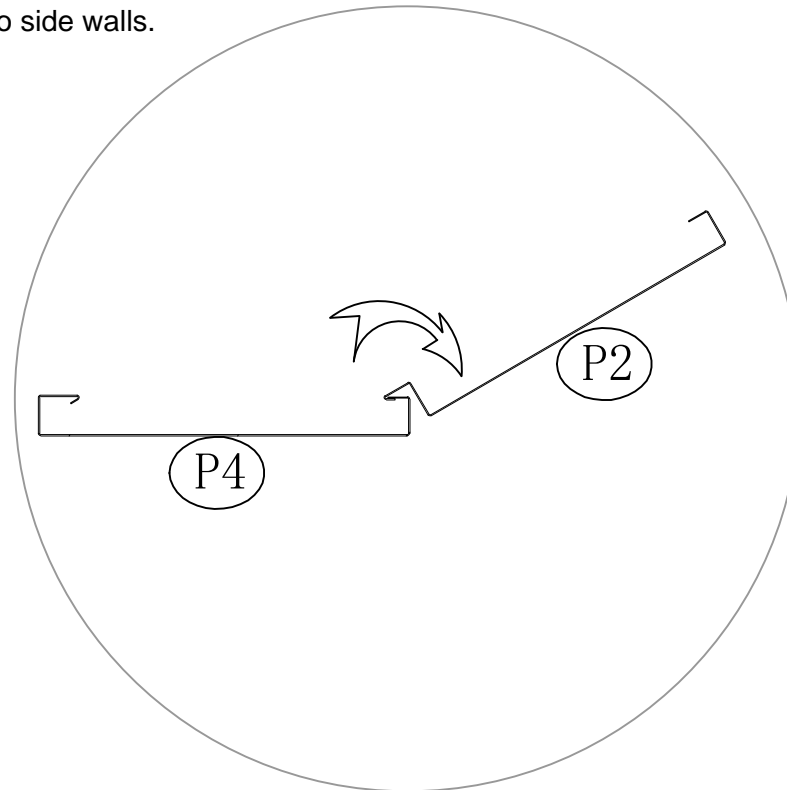
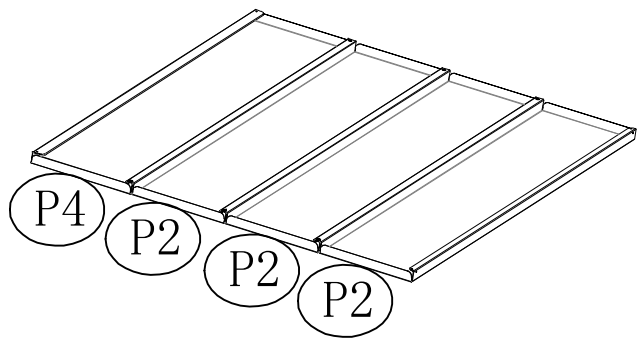

**x2**



## Wall Panels Combination

F1x 10

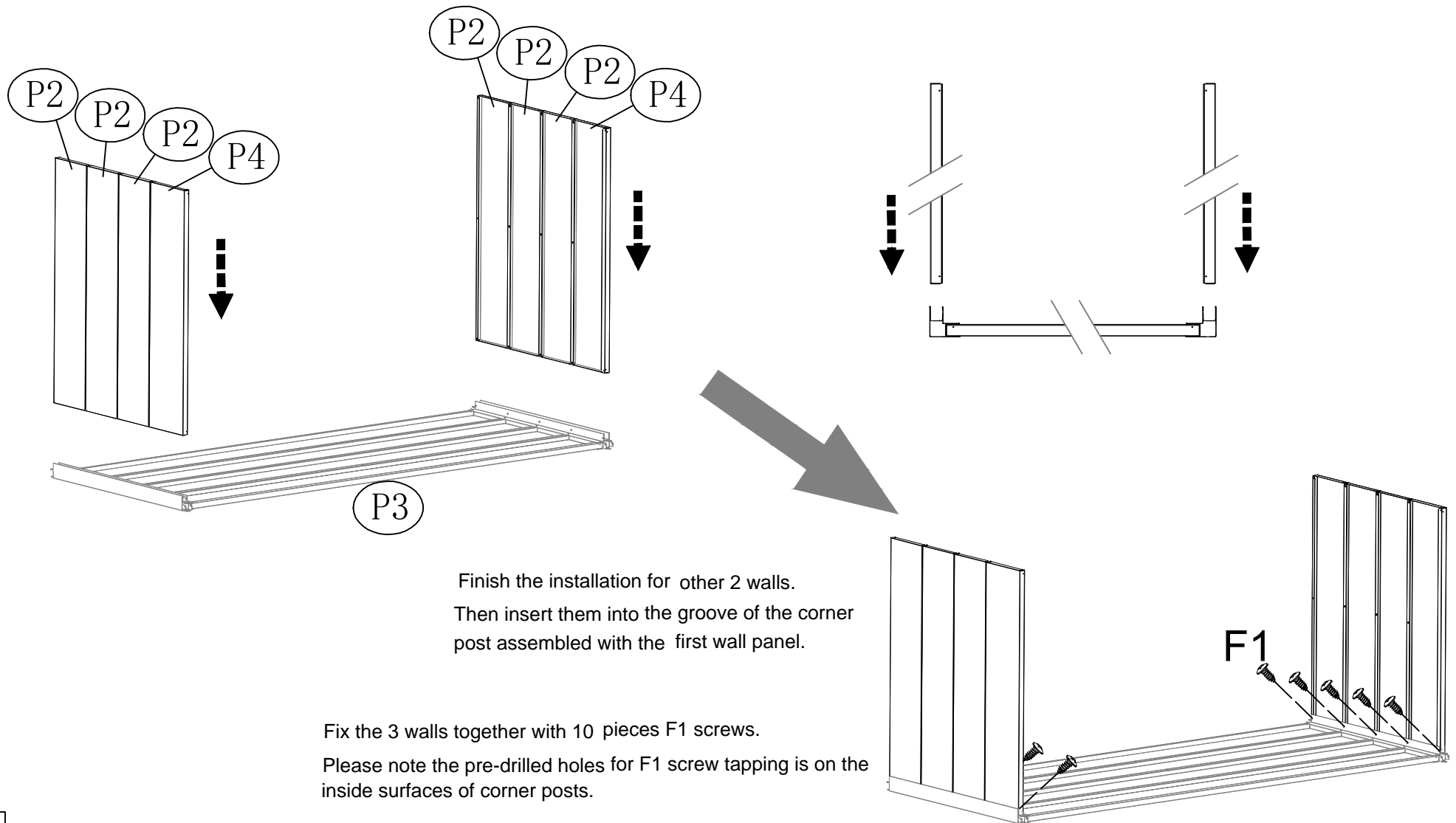





## All wall panels and corner posts assembly

F1x 10

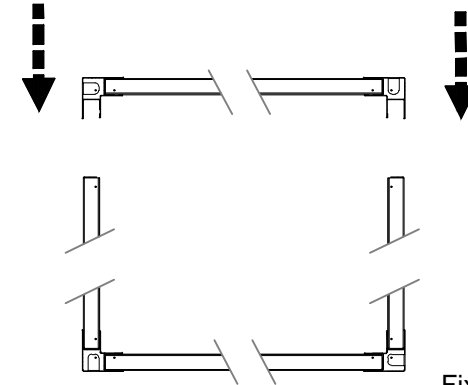
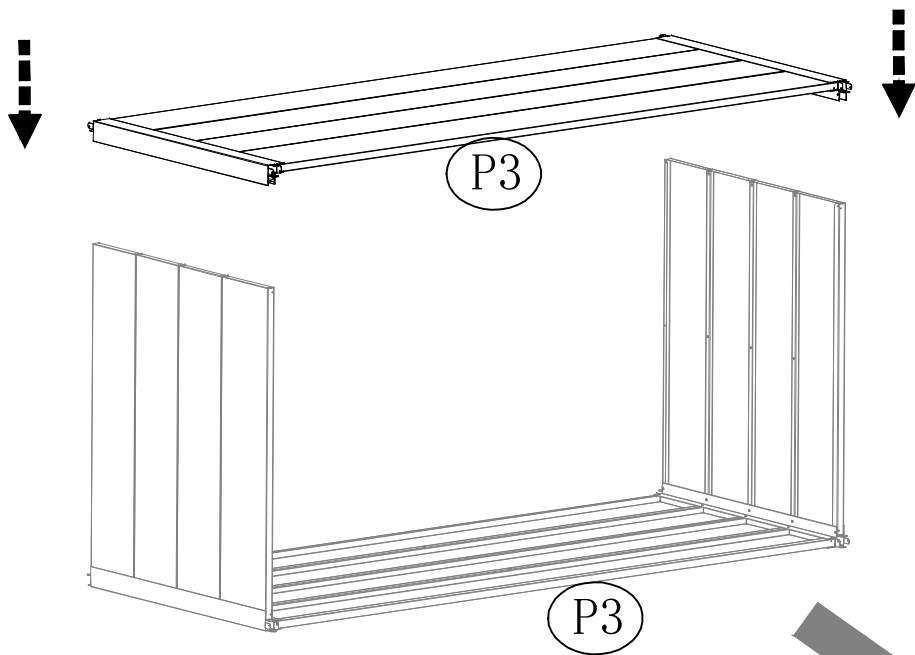

Fix the last wall panels with 10 pieces screws.

There are pre-drilled holes for screwing.

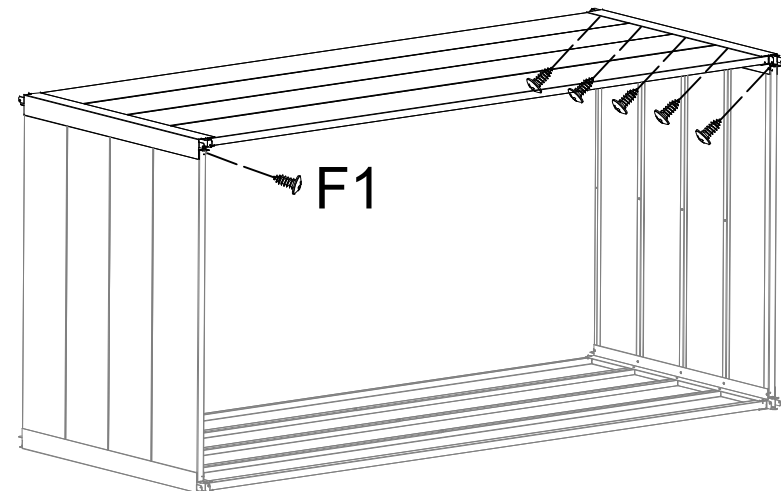



S5 x 8



C x 4



F1x 40

## Reinforcing Ribs Installation

## Corner Caps Installation

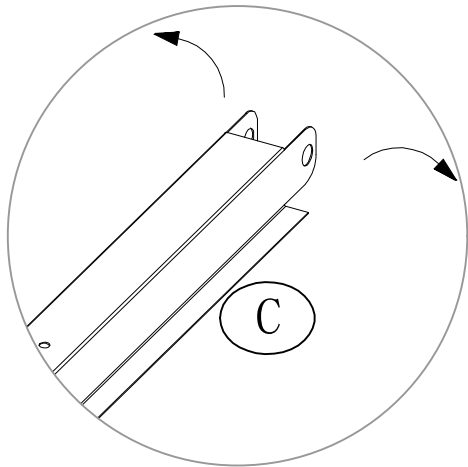

Reinforcing ribs C

Folding the top of C1 and make it in "T" the shape.

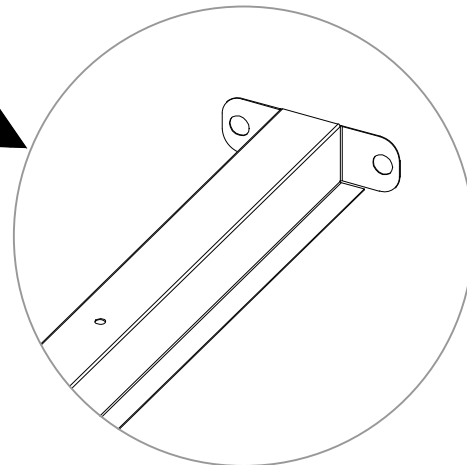

Fix the reinforcing ribs with F1 screws, 2 pieces on each end.

Please notice that there are pre-drilled holes on the wall panels.

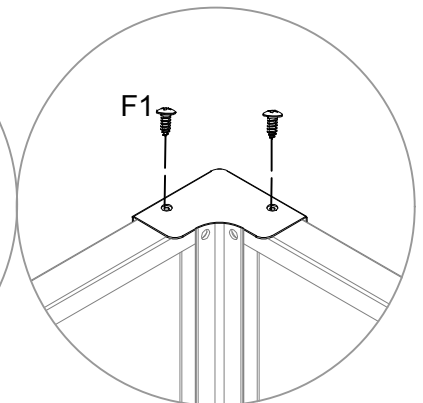
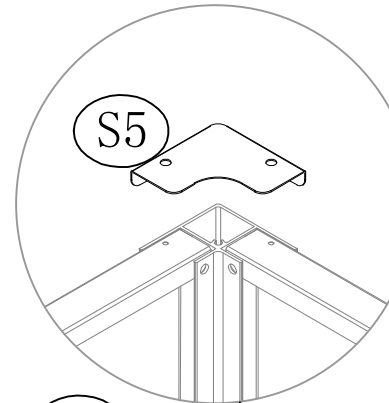

Corner Cap  
8 pieces total  
4 pieces on top  
4 pieces on bottom

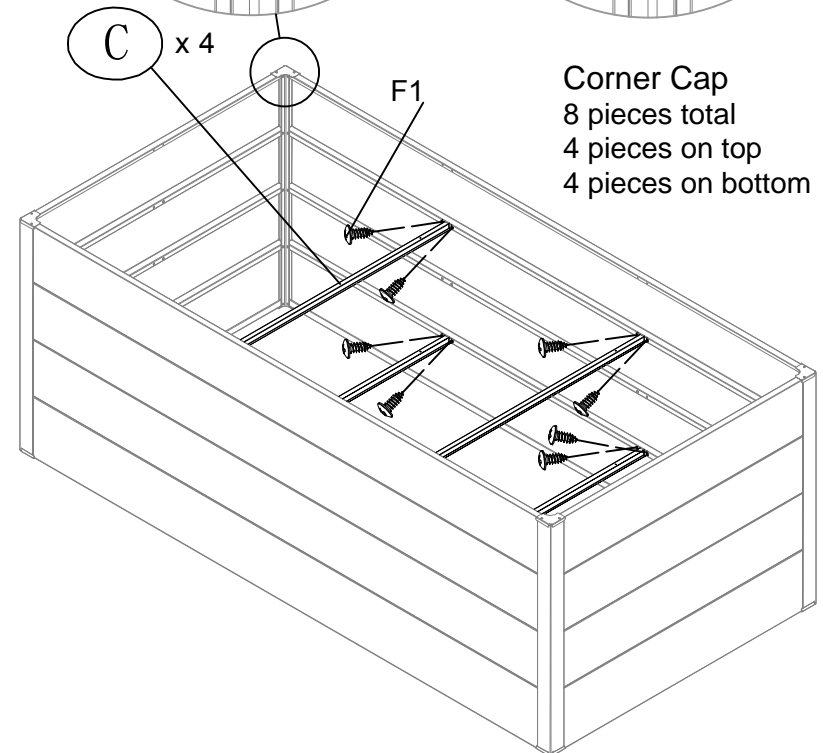



## Wall panels screwing

F1x 20

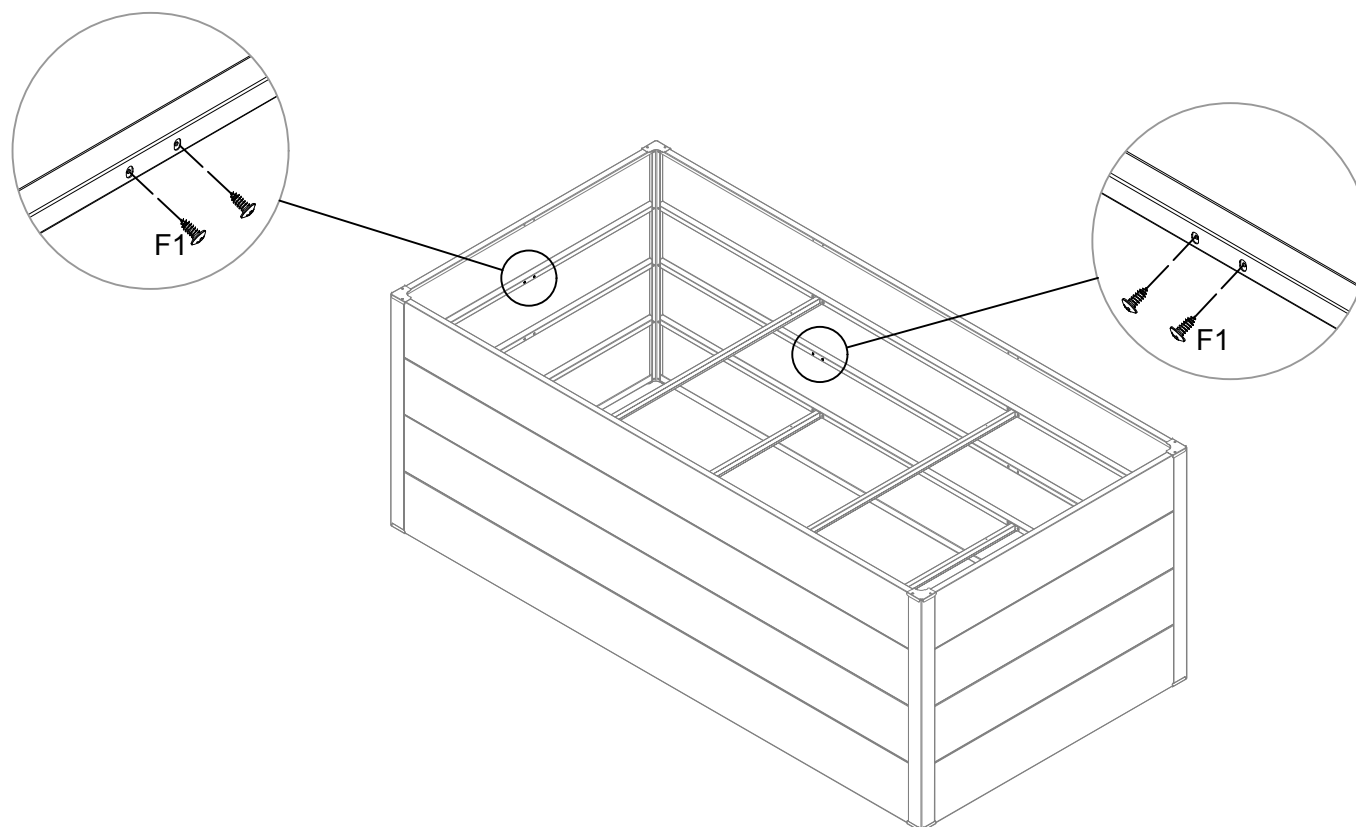

**Reinforcing the wall panels with 20 pieces F1 screws on the connecting places where there are pre-drilled holes inside of the wall panels.**

# Outdoor Products

## 1-Year Limited Warranty Program

For a period of one (1) year after purchase, Hanover (“Manufacturer”) will either repair or replace defective components in accordance with this Limited Warranty. This warranty is between Manufacturer and the original purchaser and is valid only when accompanied by the original purchaser’s sales receipt showing original date of purchase and location of purchase. Replacements under this warranty revert back to the date of original purchase for future warranty.

Manufacturer or its authorized dealer can accept or reject warranty claims based on its findings. This warranty applies in normal residential use only and is not intended for commercial use. Manufacturer can make substitutions as required of materials, components, and sub-components of comparable value and utility. This warranty is limited to product repair or replacement (to be determined solely by Manufacturer). Warranty return is limited to only the single affected component.

This warranty covers only manufacturing defects and does not cover normal wear and tear, damage due to acts of nature, abuse or misuse, including chemical damage from suntan oil or other chemicals, exposure to extreme heat or cold, abrasion or excessive weight. This product is intended to be used in standard installations only. This warranty is invalid if the product is not used for intended purpose. Manufacturer disclaims liability for any aspect of installation and any inconvenience caused by a defective part of a component.

Certain items are not covered by this warranty. These include, but are not limited to the following:

1. Items subjected to abuse, including abuse intended to simulate failure.
2. Any part which merely exhibits normal wear yet functions essentially as new, including tears/rips, chips, scratches or stretching of materials and stitching.
3. Tears, rips, punctures, scratches or any damage caused by improper installation or use.
4. Fading and/or discoloration of materials resulting from exposure to the elements, chemicals, oils, fluids or any other cause are not covered.

To make a claim, contact us by the email address or the toll-free number below. Please have available a copy of the original sales receipt along with a brief description of the problem. Please also provide your email address and daytime telephone or cell phone #. All items may be charged actual freight costs plus \$15 for handling. Repairs or replacement will be made at the Manufacturer’s option. **Sales and use taxes, plus shipping and handling charges are the responsibility of the consumer.**

**THIS IS THE ENTIRE EXCLUSIVE EXPRESS LIMITED LIABILITY. THE MANUFACTURER NEITHER MAKES NOR IS RESPONSIBLE FOR ANY OTHER WARRANTIES, EITHER EXPRESS OR IMPLIED, INCLUDING THOSE OF RETAILING DEALERS. THIS EXCLUSIVE REMEDY IS LIMITED TO RECEIPT OF A CREDIT IN CONNECTION WITH THE REPAIR OR REPLACEMENT OF ANY PRODUCT OR COMPONENT DEEMED TO BE DEFECTIVE UNDER THE TERMS AND CONDITIONS AS STATED IN THIS WARRANTY. NEITHER HANOVER, THE PRODUCT MANUFACTURER NOR ITS AGENTS SHALL BE LIABLE IN ANY CASE FOR INCIDENTAL, INDIRECT, SPECIAL OR CONSEQUENTIAL DAMAGES RESULTING FROM THE USE OF THIS PRODUCT OR ARISING OUT OF ANY BREACH OF THIS WARRANTY OR NEGLIGENCE EVEN IF IT HAS BEEN ADVISED OF THE POSSIBILITY OF SUCH DAMAGES. EXCEPT AS OTHERWISE MAY BE REQUIRED BY LAW, THERE ARE NO OTHER EXPRESS OR IMPLIED WARRANTIES OTHER THAN THE WARRANTY DESCRIBED HEREIN, AND ALL OTHER WARRANTIES, INCLUDING ANY IMPLIED WARRANTY OF MERCHANTABILITY OR FITNESS FOR A PARTICULAR PURPOSE ARE EXPRESSLY DISCLAIMED.**

**Contact Warranty Services at 1-877-397-5144**

Or email us at:

**ContactUs.Hanover-Products.com**

or

**www.Hanover-Products.com**

# Snail Border for 9820503 Garden Bed

## Instructions for Assembly

---

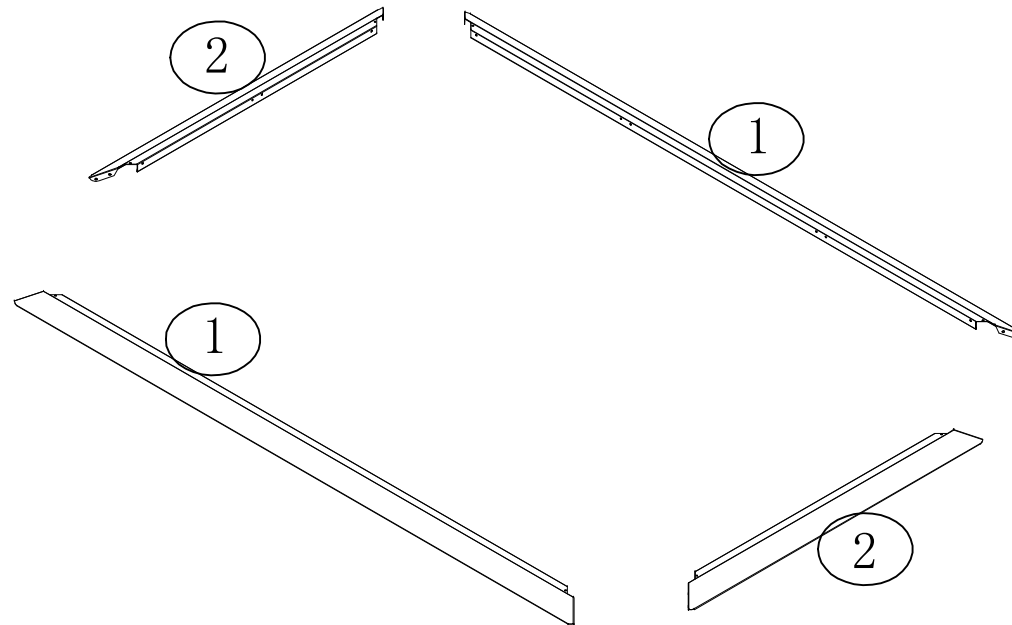

**9820503-SB**



# IMPORTANT

If you have any problems with this product, please

**DO NOT RETURN THIS ITEM**

To the Retailer/Store from where you purchased the product.

Please email us anytime with the nature of the problem at:

**ContactUs@Hanover-Products.com**

Please include:

- Pictures of the issue(s) and receipt (if available)
- Name and address of the Purchaser
- Name of retailer

Or call our Customer Service team between 9:00 AM and 5:00 PM Eastern Time,  
Monday through Friday at:

**1-877-397-5144**

or visit our website at:

**www.Hanover-Products.com**

To expedite any future warranty claims, please retain your receipt for future use.



For additional on-line support on assembly, troubleshooting and care & maintenance of your outdoor product, please visit our website at: **www.Hanover-Products.com**.

8/1/2019

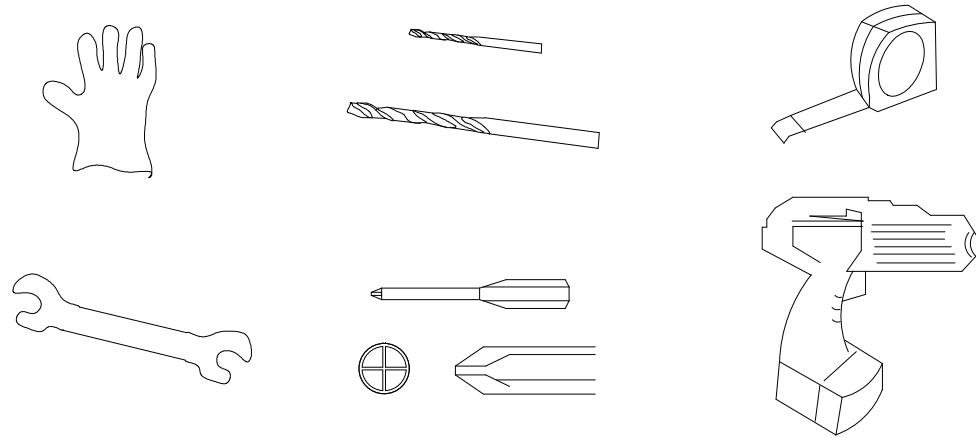
## Tools may needed

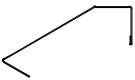
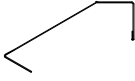
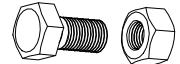

Use heavy duty gloves when handling steel sheets and flashing

NO.	Part List	Qty.
1	 2121 mm 83.5"	2
2	 1121 mm 44"	2
F7		8
ST4		8
F1		15

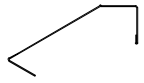

1 x 2

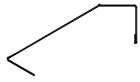

2 x 2

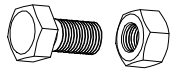

F7 x 8

### Snail Border Installation

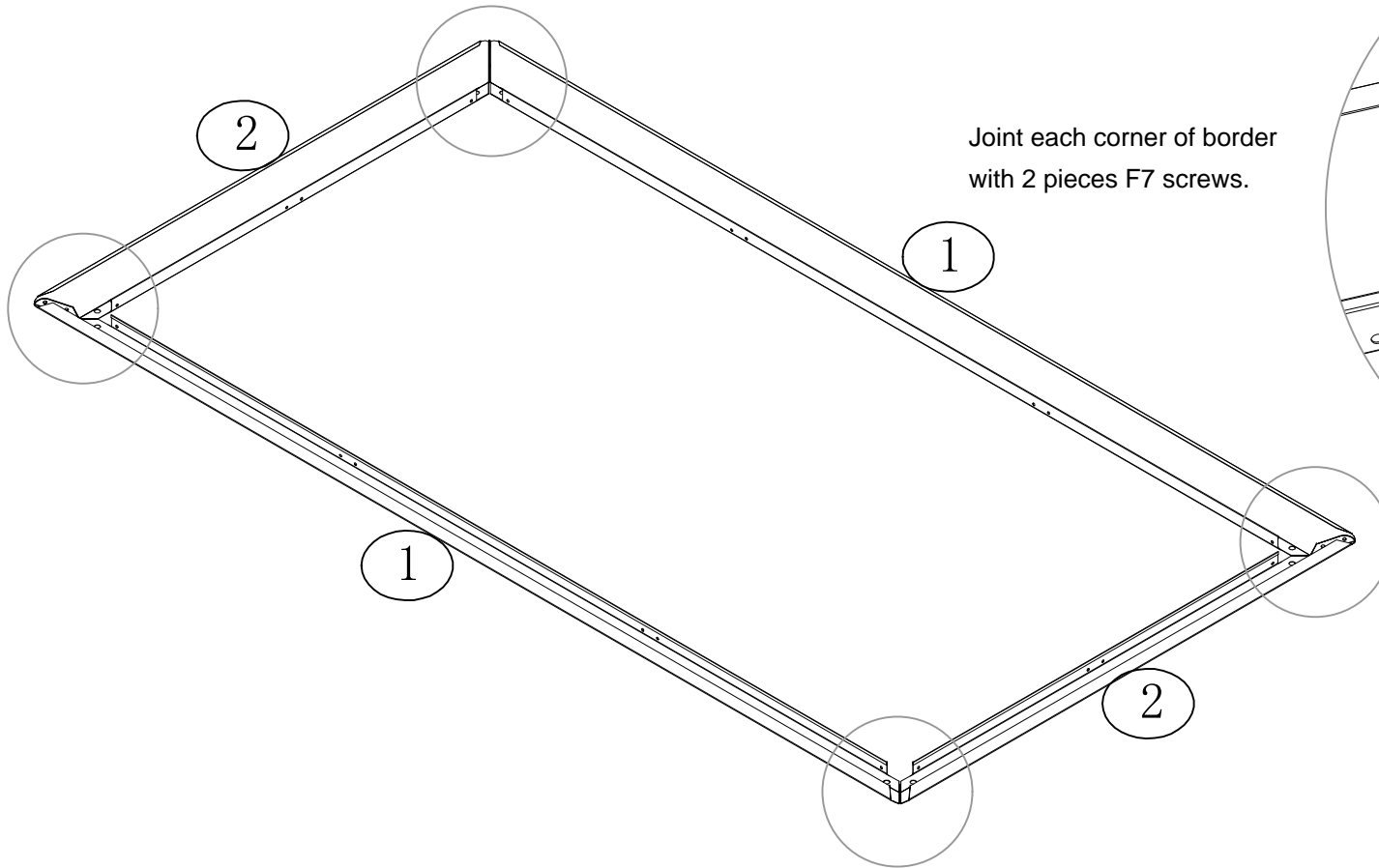

Joint each corner of border with 2 pieces F7 screws.

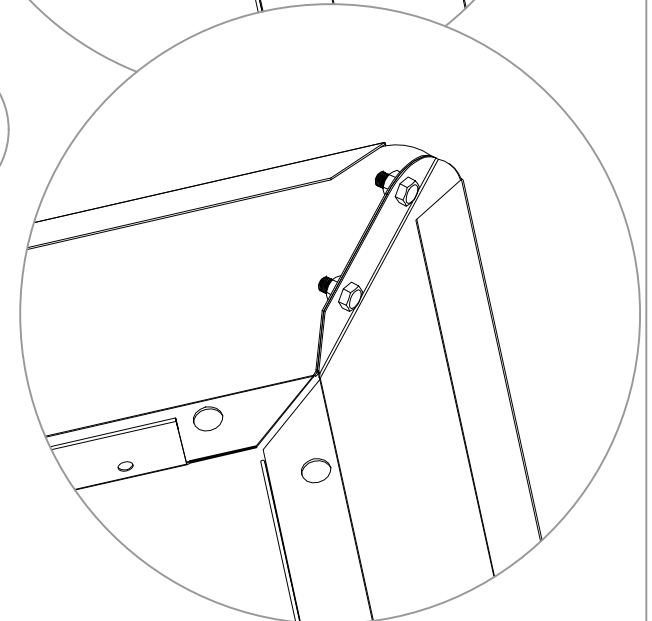
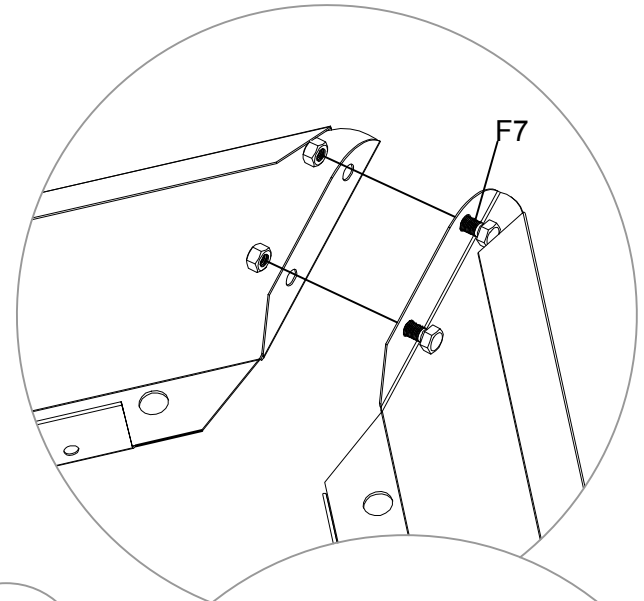



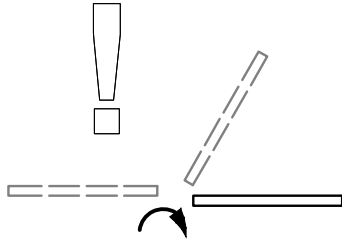

## Snail Border & Plant Bed Combination

Overturn the snail border and cover it onto the plant bed.

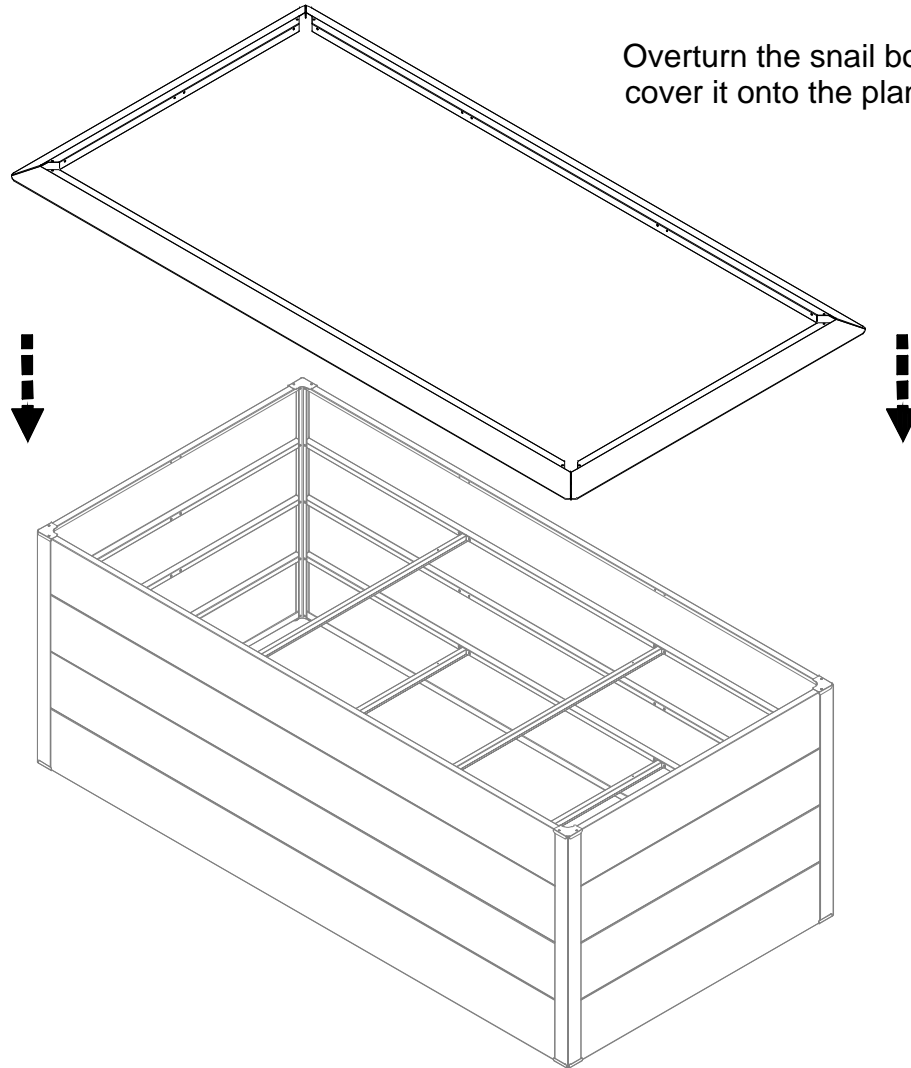



F1x 12



ST4 x 8

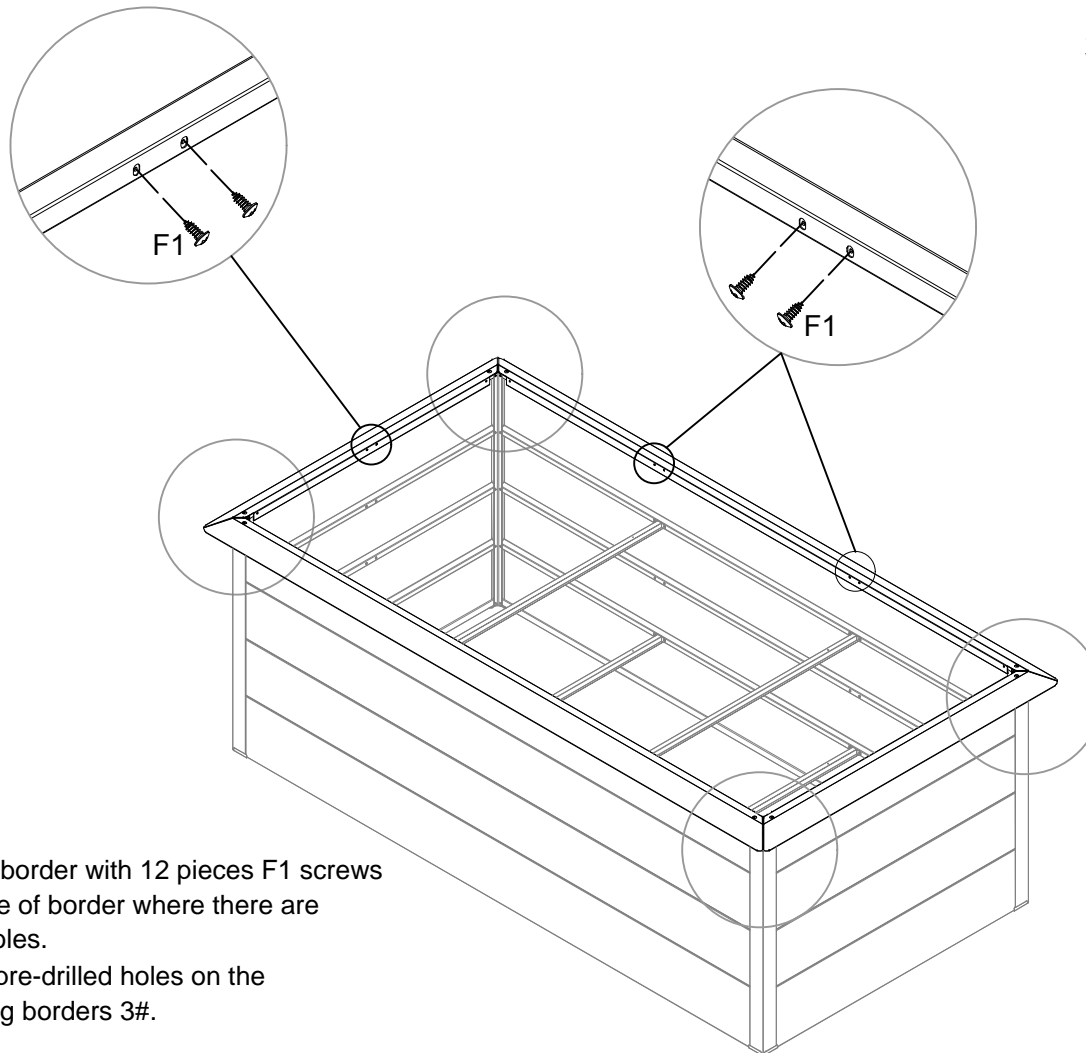

Fix the snail border with 12 pieces F1 screws on the middle of border where there are pre-drilled holes.

There are 4 pre-drilled holes on the middle of long borders 3#.

## Snail Border & Plant Bed Screwing

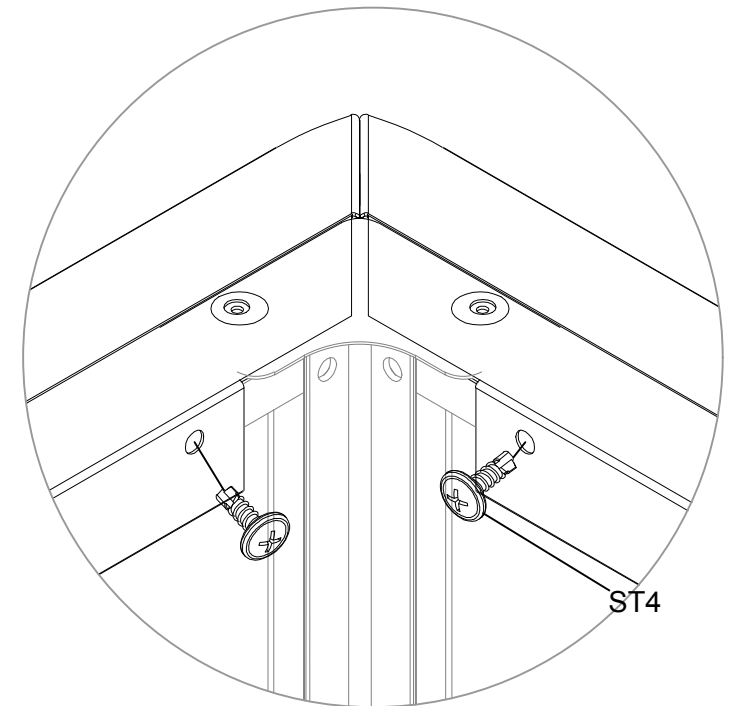

Fix the snail border on plant bed with 8 pieces ST4 self-tapping screws at the corners. 2 pieces screws needed each corner.



# IMPORTANT

If you have any problems with this product, please

**DO NOT RETURN THIS ITEM**

To the Retailer/Store from where you purchased the product.

Please email us anytime with the nature of the problem at:

**ContactUs@Hanover-Products.com**

Please include:

- Pictures of the issue(s) and receipt (if available)
- Name and address of the Purchaser
- Name of retailer

Or call our Customer Service team between 9:00 AM and 5:00 PM Eastern Time,  
Monday through Friday at:

**1-877-397-5144**

or visit our website at:

**[www.Hanover-Products.com](http://www.Hanover-Products.com)**

To expedite any future warranty claims, please retain your receipt for future use.

For additional on-line support on assembly, troubleshooting and care & maintenance of your outdoor product, please visit our website at: **[www.Hanover-Products.com](http://www.Hanover-Products.com)**.

# Outdoor Products

## 1-Year Limited Warranty Program

For a period of one (1) year after purchase, Hanover (“Manufacturer”) will either repair or replace defective components in accordance with this Limited Warranty. This warranty is between Manufacturer and the original purchaser and is valid only when accompanied by the original purchaser’s sales receipt showing original date of purchase and location of purchase. Replacements under this warranty revert back to the date of original purchase for future warranty.

Manufacturer or its authorized dealer can accept or reject warranty claims based on its findings. This warranty applies in normal residential use only and is not intended for commercial use. Manufacturer can make substitutions as required of materials, components, and sub-components of comparable value and utility. This warranty is limited to product repair or replacement (to be determined solely by Manufacturer). Warranty return is limited to only the single affected component.

This warranty covers only manufacturing defects and does not cover normal wear and tear, damage due to acts of nature, abuse or misuse, including chemical damage from suntan oil or other chemicals, exposure to extreme heat or cold, abrasion or excessive weight. This product is intended to be used in standard installations only. This warranty is invalid if the product is not used for intended purpose. Manufacturer disclaims liability for any aspect of installation and any inconvenience caused by a defective part of a component.

Certain items are not covered by this warranty. These include, but are not limited to the following:

1. Items subjected to abuse, including abuse intended to simulate failure.
2. Any part which merely exhibits normal wear yet functions essentially as new, including tears/rips, chips, scratches or stretching of materials and stitching.
3. Tears, rips, punctures, scratches or any damage caused by improper installation or use.
4. Fading and/or discoloration of materials resulting from exposure to the elements, chemicals, oils, fluids or any other cause are not covered.

To make a claim, contact us by the email address or the toll-free number below. Please have available a copy of the original sales receipt along with a brief description of the problem. Please also provide your email address and daytime telephone or cell phone #. All items may be charged actual freight costs plus \$15 for handling. Repairs or replacement will be made at the Manufacturer’s option. **Sales and use taxes, plus shipping and handling charges are the responsibility of the consumer.**

**THIS IS THE ENTIRE EXCLUSIVE EXPRESS LIMITED LIABILITY. THE MANUFACTURER NEITHER MAKES NOR IS RESPONSIBLE FOR ANY OTHER WARRANTIES, EITHER EXPRESS OR IMPLIED, INCLUDING THOSE OF RETAILING DEALERS. THIS EXCLUSIVE REMEDY IS LIMITED TO RECEIPT OF A CREDIT IN CONNECTION WITH THE REPAIR OR REPLACEMENT OF ANY PRODUCT OR COMPONENT DEEMED TO BE DEFECTIVE UNDER THE TERMS AND CONDITIONS AS STATED IN THIS WARRANTY. NEITHER HANOVER, THE PRODUCT MANUFACTURER NOR ITS AGENTS SHALL BE LIABLE IN ANY CASE FOR INCIDENTAL, INDIRECT, SPECIAL OR CONSEQUENTIAL DAMAGES RESULTING FROM THE USE OF THIS PRODUCT OR ARISING OUT OF ANY BREACH OF THIS WARRANTY OR NEGLIGENCE EVEN IF IT HAS BEEN ADVISED OF THE POSSIBILITY OF SUCH DAMAGES. EXCEPT AS OTHERWISE MAY BE REQUIRED BY LAW, THERE ARE NO OTHER EXPRESS OR IMPLIED WARRANTIES OTHER THAN THE WARRANTY DESCRIBED HEREIN, AND ALL OTHER WARRANTIES, INCLUDING ANY IMPLIED WARRANTY OF MERCHANTABILITY OR FITNESS FOR A PARTICULAR PURPOSE ARE EXPRESSLY DISCLAIMED.**

Contact Warranty Services at **1-877-397-5144**

Or email us at:

**ContactUs.Hanover-Products.com**

or

**www.Hanover-Products.com**